

# Tech Note

## Antenna Mounting Guidelines

This tech note outlines some important concepts to consider when mounting antennas for telemetry systems and provides information on best-practice methods for locating and installing antennas for use with Observant products.

### Locating Antennas

#### Maximize Communication Effectiveness

- Antennas for 900MHz ISM radios (and cellular modems) need “line of sight” to perform their best. Be sure it is possible to see the antenna at the other end of the link without any intervening obstructions.
- Do not forget that crops themselves can grow to heights that could mask radio signals.
- Given the nature of radio wave transmission, the longer the distance between links, the greater the vertical clearance required, as depicted in the Figure 1.
- Thus, the higher the antenna, the better the performance. Mount gateway antennas as high as possible. (An ideal location would be a nearby hilltop, in sight of all its nodes.)

#### Avoid Interference with Adequate Separation

- To prevent mutual interference, 900 MHz and cellular antennas on the same structure need a 20” (500 mm) minimum separation—both vertically and horizontally.
- Likewise, antennas should be mounted at least 20” (500 mm) above maximum crop (or tree) height.
- For gateway installations, always position the 900 MHz antenna above the cellular antenna.

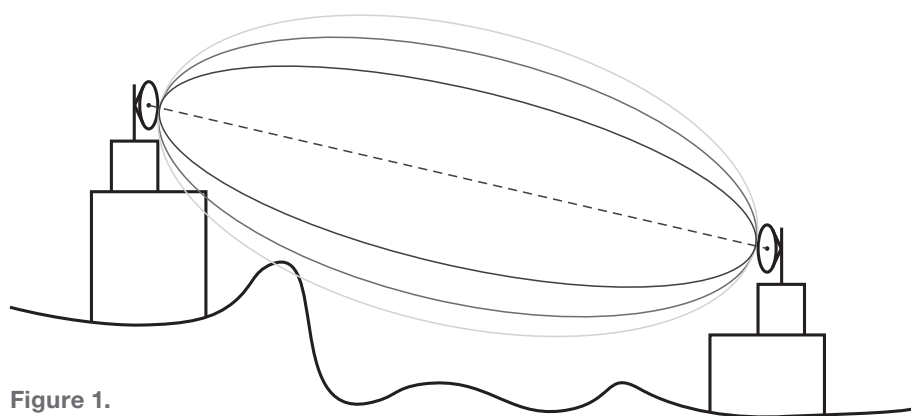

Figure 1.  
Line of sight

- The proximity of any metal can dramatically affect an antenna's effectiveness. Make sure antennas are at least half their length away from mounting poles (or any other substantial piece of metal).

### Further Precautions

- Take particular care when mounting antennas in areas that may have limitations imposed by overhead irrigation or spray equipment. Be sure (in advance) that such machinery will not interfere with any telemetry installations in the field.
- In cases where it is not possible to achieve sufficient height to assure line-of-sight communication, it may be necessary to, for example, install a node at the edge of a field and run cabling to the relevant sensor(s).
- If trimming foliage to maximize communication, remember that nearby plants should be left intact to act as reference plants when determining the soil moisture of the local hydro-zone.

### Mounting Antennas

#### Pole or Telespar-style Installations

- Mount antennas as high as possible within the constraints of the mounting hardware.
- Above a certain height, local regulations (and common sense) may require poles to be guy-wired.
- When properly engineered, free-standing poles up to about 30 ft (5 m) high are possible.
- For ease of installation, telescoping sections of Telespar-type, square, perforated, steel tubing allow antenna masts to be raised from ground level (avoiding the need for heavy, lift-machinery at the site).
- Free-standing structures (such as windmills) may also provide useful alternatives.

### Observant C3 Enclosure Mounting

- The C3 Enclosure has a 16 mm hole designed to accept box-mounted antennas.
- For sites where telemetry units are relatively close and have good lines of sight between them, a simple, cost-effective installation can be made by mounting antennas directly to their unit's C3 Solar Enclosure.
- In these cases, the Enclosure should be situated at the very top of its pole (to keep the pole's metal from interfering with the antenna's signal).

### Cabling Considerations

- It is important to protect antenna cabling from the sun, rain, animals, or machinery that may cause damage.
- With pole-mounted antennas, the pole itself may provide an appropriate conduit to protect the cable. With suitable holes drilled, cables can be routed out of the enclosure directly into the pole and exit to connect to the antenna mounted at the top of the pole.
- Alternatively, UV-stable, rigid or flexible conduit can be used to route the cable alongside the antenna mounting structure.
- To avoid the entry of insects, be sure to seal appropriately all cables exiting a telemetry enclosure.

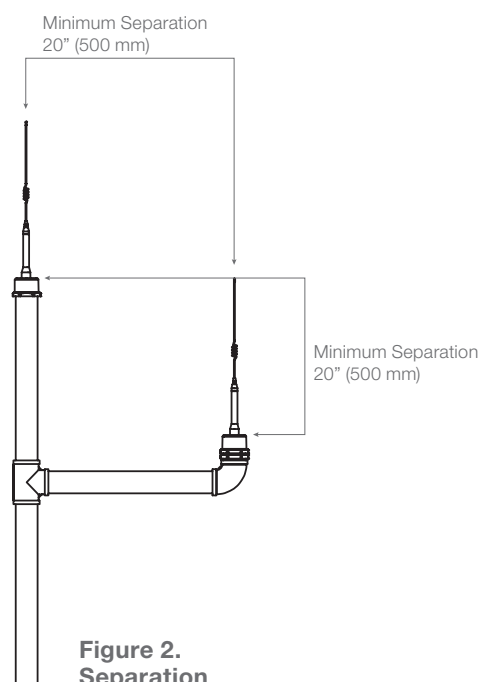

Figure 2.  
Separation

OBS-USR-TN007-R1

