

Tech Note

Electric Pump Control

The Observant C3 Platform can remotely start and stop an electric motor by activating the contactor which supplies power to the motor as described in this Technical Note. Connection of a C3 to an electric motor according to this Technical Note should only be performed by an experienced electrician. Remote control capability should not replace local on/off control or any other fail-safe hardware. An Emergency Stop button and appropriate power disconnects should always be in place at the same location as the motor.

Application

The digital outputs of the C3 can be used to control contactors associated with the running of electric pumps (non-VSD systems). When combined with a feedback mechanism described in subsequent sections, a complete electric pump control and monitoring system can be realized.

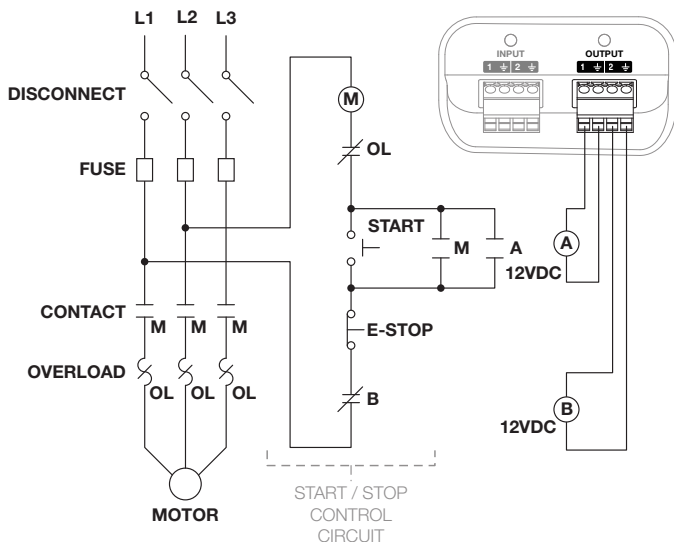

Figure 1.
Latching Momentary Start / Stop

Electrical connection

- Electrical motor contactors are typically controlled by high-voltage AC supplies. These need to be controlled by the nominal 12 VDC outputs of the C3 by using 12 VDC coil, mains rated contact relays.
- In a latching Start/Stop control circuit, the C3 uses two outputs to control two 12 VDC coil relays. A NO “Start” relay is wired in Parallel with the existing NO momentary pushbutton Start switch, and an NC “Stop” relay is inserted in Series with the existing NC momentary Stop switch. Both relays can be pulsed by the C3 to emulate momentary switches.
- Figure 1 shows a typical latching Start/Stop circuit interfaced with a C3. Relays A and B are added as shown to allow remote control. All other components in the figure are existing.
- Figure 2 shows a typical RUN-OFF-AUTO control circuit controlled with a C3 in when in AUTO mode. Relay A is added as shown to allow remote control. In this case, Relay Coil A is energized continuously by the C3 (not pulsed) when the motor is running.
- Note that in both figures all existing safety components including disconnects, fuses, overload protection and emergency stops are left in place without modification.

Installation notes

- It is typical for the C3 and associated wiring to be housed within the same switch box as the electric pump contactor.
- Both the C3 and the relay(s) can be mounted on standard, 25 mm DIN rail.
- A 12 VDC power supply will need to be installed and connected to the auxiliary power input of the C3. This ensures that the C3 has enough power to keep the relay coils energized.

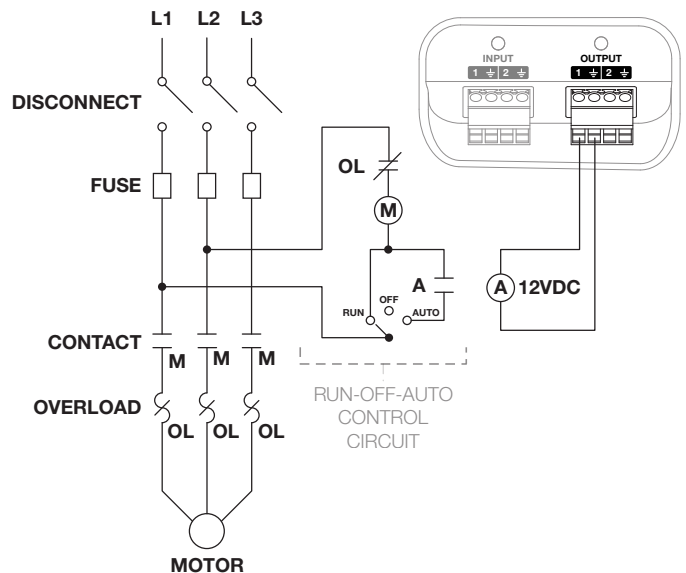

Figure 2.
Run-Off-Auto Switch

OBS-USR-TN004-R1

