

PUMP MANAGEMENT

Monitors and controls pumps remotely. The Pump Management solution allows you to be aware of the status of your pump systems and to start and stop them remotely. Remote monitoring and control reduces labor, improves maintenance and enhances your ability to react to changing conditions. Monitor and control an on/off electric pump or, through an Observant-supported interface, monitor and control a diesel-engine driven pump. Combine with other Observant solutions to maintain reservoir water-levels or schedule and supply an irrigation system.

Applications

- Irrigation management.
- Reservoir management.
- Fertigation.
- Energy management.

Related Solutions

- Flow and Line Pressure Monitoring.
- Irrigation Scheduling.
- Water Level Monitoring.
- Diesel Engine Management.
- Energy Monitoring.

Observant Platforms

- C3 Gateway.
- C3 Cell.
- C3 Node.
- Solo Cell.
- Pico.

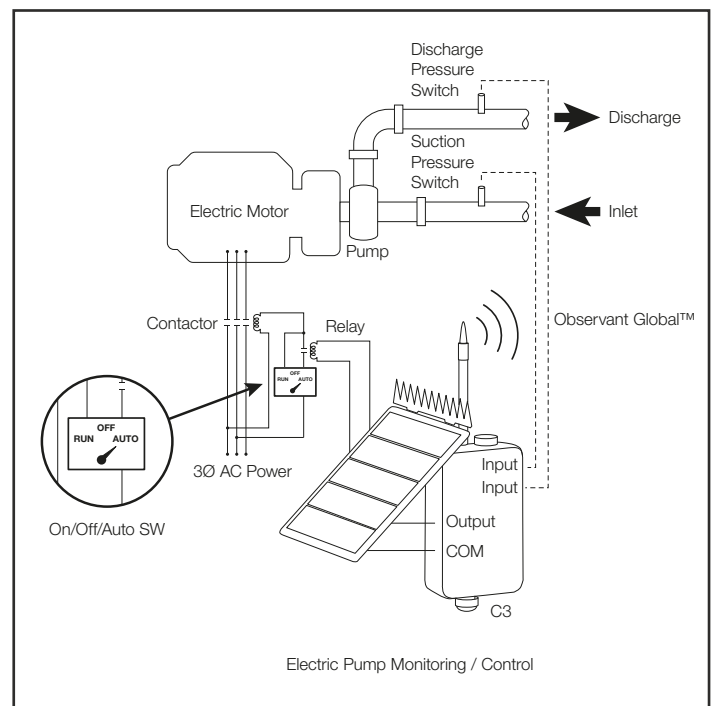
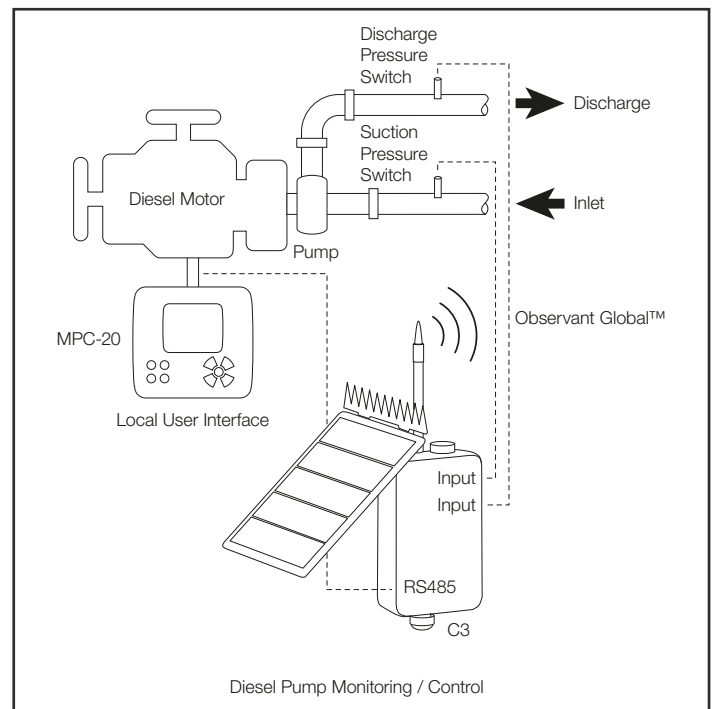

I/O Type and Connection

Electric Pumps

Electric pumps interface with an Observant Telemetry platform using one or two DC coil relays depending on configuration. In most implementations one or two normally open DC coil relays are used to control an appropriately rated high voltage contactor which can establish or interrupt the power supply to the pump motor. Connect the 12 volt relay coils to the Dual Purpose Switched Outputs 1-4 on the C3 or the two High Current Outputs of the Solo. Interfacing a Telemetry Unit with an electric pump should only be performed by a qualified electrician. For more information see Observant Technical Note OBS-USR-TN004: Electric Pump Control.

Diesel Pumps

Certain diesel engine powered pumps which utilize the Enovation Controls Murphy MPC-20 Diesel Engine Controller can be interfaced with the RS485 port on a C3 Telemetry Unit. Interfacing a Telemetry Unit with a Murphy MPC-20 controller requires custom modifications to the controller setup which should only be performed by the pump manufacturer or a highly qualified integrator. Specific manufacturers who can provide this feature are shown in the "Supported Devices" section of this document.

Flow Switches, Pressure Switches

Connect flow switches and pressure switches to the C3 or Solo Dual Purpose Digital/Analog Inputs (Inputs 1-4).

Capabilities

Remotely Start and Stop Pump

Start and stop your pump using Observant Global™ on your desktop computer or smartphone.

Automatically Start and Stop Pump

When used in conjunction with the Irrigation Scheduling solution, pumps can be automatically run by a pre-programmed irrigation schedule. Pump start and stop can be timed with valve actions to avoid dangerous deadhead conditions.

Monitor Pump Run Status

Know when your pump is running. This information can be used directly, or as an input to other Observant solutions such as Irrigation Scheduling. Receive alerts if the pump shuts down due to an alarm or failure.

Monitor and Track Run Time

Keep track of pump runtime and use this information to schedule maintenance and other operations.

Monitor Pump Input/Output

Monitor pump intake and output through flow and/or pressure switches to confirm proper operation. Text message alerts can be issued if low flow or pressure conditions indicate problems.

Monitor Pump Alarms (Diesel / MPC-20 applications)

Remotely monitor pump alarm status. Alerts can be issued on the occurrence of any alarms reported by the engine controller including low oil pressure, high temperature, low fuel and many others. See Murphy MPC-20 Operation Manual for a complete list of alarm conditions.

Integrate With Other Observant Solutions

Use Pump Management as a key component of Irrigation Scheduling, Water Level Control and Energy Management.

Supported Devices

- DC Motor Pump controlled with relay closure (Observant Tech Note OBS-USR-TN004).*
- AC Induction Motor Pump controlled with relay closure (Observant Tech Note OBS-USR-TN004).*
- Pressure Switch, Normally Open Relay Output.
- Flow Switch, Normally Open Relay Output.
- Diesel engines enabled by Enovation Controls Murphy MPC-20 Diesel Engine Control.**

* On-site installation including starter (if applicable), drive (if applicable), contactor, emergency stop and appropriate fail-safe circuits not provided by Observant. Observant C3 will interface with 12VDC relay coil for on-off control. See Observant Technical Note OBS-USR-TN004: Electric Pump Control.

** Specific pump/engine packages can be purchased integrated with Observant telemetry units. These include certain pumps/engines supplied by Pivot Power, Inc., Sioux Falls, SD. Pumps not integrated with an Observant telemetry package as-supplied must be controlled by the Enovations Controls Murphy MPC-20 and must be custom integrated by the pump/engine supplier or a qualified integrator.

SAFETY DISCLAIMER

Pump must be installed by a qualified electrician and/or mechanic. Fail-safe circuits must be included that are appropriate for remote operation. Remote monitoring and/or control through the Observant platform does not constitute or replace hard-wired safety shutoffs.